



TEXAS SOUTHMOST COLLEGE DISTRICT  
THE UNIVERSITY OF TEXAS AT BROWNSVILLE and TEXAS SOUTHMOST COLLEGE

80 Fort Brown • Brownsville, Texas 78520 • (956) 882-3879 • Fax: (956) 882-8811 • <http://blue.utb.edu/vppa>

FILED AND RECORDED  
OFFICIAL PUBLIC RECORDS  
On: Nov 11, 2009 at 03:14P

Joe G. Rivera  
County Clerk  
By  
Hilda Perez, Deputy  
Cameron County

Official Notice of the

**Texas Southmost College District  
Regular Meeting**

for  
**May 14, 2009**

Posted

May 11, 2009

**AGENDA**

The Board of Trustees of the Texas Southmost College District will convene **Thursday, May 14, 2009, at 5:30 p.m.** in the Gorgas Board Room at The University of Texas at Brownsville and Texas Southmost College, 80 Fort Brown, Brownsville, Texas 78520.

**Call to Order**

**1 Announcements**

**Introduction** of New Associate Vice President for Institutional Advancement

**2 Acceptance of Gift and Resolution**  
Consideration and possible action on:

**Adoption** of Resolution Naming The Arts Center Box A the "Charles and Elizabeth Stillman Box"

**3 Speakers to Agenda Items and Public Discussion**

**Board of Trustees**

*David G. Oliveira*

*Chair*

*Eduardo A. Campirano*

*Vice Chair*

*Roberto Robles, M.D.*

*Secretary*

*Adela G. Garza*

*Chester Gonzalez*

*Rosemary Breedlove*

*René Torres*

**UTB/TSC President**

*Juliet V. Garcia, Ph.D*

**4 Approval of minutes of previous meetings**

Consideration and possible action on:

**Regular Meeting, April 23, 2009**

**5 Board Briefing**

**The Math & Science Academy**  
Edward Argueta, Principal

**6 Executive Session**

as provided by Government Code, Chapter 551.071 and .072

**Real Estate**

**Contract** and Resolution for Purchase of Lot 1, Block 1, University Park Subdivision, Brownsville, Texas.

**Contract** and Resolution for Purchase of Lots 21 and 22, Block 10, Colonia Alta Vista Subdivision, Brownsville, Texas.

**Legal Matters**

**Authorize** the Funding of a Security Contract through UTB/TSC for the New Library and Classroom Buildings.

**7 Consideration and possible action on matters discussed in Executive Session**

**Real Estate**

**Contract** and Resolution for Purchase of Lot 1, Block 1, University Park Subdivision, Brownsville, Texas.

**Contract** and Resolution for Purchase of Lots 21 and 22, Block 10, Colonia Alta Vista Subdivision, Brownsville, Texas.

**Legal Matters**

**Authorize** the Funding of a Security Contract through UTB/TSC for the Library and Classroom Buildings.

**8 Physical Facilities Committee**

Consideration and possible action on:

**Report**

**Awarding** a Contract for Netting Support System for the REK Center

**Change Order** to the Contract with Skanska USA for the Library Mural

**Substantial** Completion of the Construction of the New Library and Classroom Buildings

**9 Construction Report**

**Commissary** Building, Campus Security Center, Commandant's Quarters, Rusteberg Landscaping, Amphitheater Parking Lot, Cavalry Renovation, Ringgold Sidewalk, 21<sup>st</sup> Street Parking Lot, Palm Trees, Gorgas Drive Entrance, Center for Early Childhood Studies, Arts Center, Science & Technology Center, REK Center Parking Lot

**10 President's Report**

**NIH1** Forum Held, ADN Pinning Ceremony, Ring Ceremony, Distinguished Guest Ceremony, Commencement

**11 Proposed Meeting Dates**

Board Meetings:

**Thursday, June 18, 2009**

**July – No Meeting**

**Thursday, August 27, 2009**

**Thursday, September 17, 2009**

**Adjournment**

THE STATE OF TEXAS §

COUNTY OF CAMERON §

## TEXAS SOUTHMOST COLLEGE DISTRICT

### RESOLUTION

*WHEREAS*, Mr. Alexander Stillman been an outstanding friend and supporter of The University of Texas at Brownsville and Texas Southmost College; and

*WHEREAS*, Mr. Alexander Stillman has been a strong advocate for education, the arts, health, history, and historic building preservation; and

*WHEREAS*, Mr. Alexander Stillman's great grandparents, Charles and Elizabeth Stillman, were pioneers in South Texas and founders and developers of Brownsville in 1848.

*WHEREAS*, Mr. Alexander Stillman today and Charles and Elizabeth Stillman - in their day - have strived to improve the quality of life in Brownsville and for humanity internationally;

*WHEREAS*, music education and the visual and performing arts at The University of Texas at Brownsville and Texas Southmost College and in the Rio Grande Valley will be nurtured in The Arts Center for many years to come;

*NOW, THEREFORE, BE IT RESOLVED* by the Board of Trustees of the Texas Southmost College District that Box A in The Arts Center will be named

“The Charles and Elizabeth Stillman Box.”

*ADOPTED this 14th day of May 2009.*

---

David Oliveira  
Chair, Board of Trustees

---

Roberto Robles, M.D.  
Secretary, Board of Trustees

## **Texas Southmost College District**

### Minutes of the Regular Meeting of the Board of Trustees

April 23, 2009

The Board of Trustees of the Texas Southmost College District convened in open session on April 23, 2009, at 4:30 p.m., in the Board Room of Gorgas Hall, The University of Texas at Brownsville and Texas Southmost College. Board members present were David Oliveira, Chair, Eduardo A. Campirano, Vice Chair, Dr. Roberto Robles, Secretary, Chester Gonzalez, and Adela Garza. Absent were Rosemary Breedlove and René Torres. Also present was Dr. Juliet V. García, President of The University of Texas at Brownsville and Texas Southmost College.

#### **Call to Order**

The meeting was called to order by Chairman Oliveira at 4:36 p.m.

#### **1. Announcements**

There were no announcements.

#### **2. Speakers to the Items and Public Discussion**

UTB/TSC students Erasmo Castro, Rosalinda Rangel, Jorge Munoz, and Ruby de la Fuente students of UTB/TSC discussed issues regarding the Student Government Association.

### **3. Acceptance of Gift and Resolution**

#### **Consideration and possible action on adoption of resolution naming The Arts Center Box B “The Villarreal-Montemayor Family Box”**

Dr. Ruth Ann Ragland, Vice President for Institutional Advancement, announced the acceptance of a gift from Alejandro and Irma Villarreal. Dr. Ragland provided a brief biography of Alejandro and Irma Villarreal as community leaders in promoting education, economic development, and the fine arts. Mr. Oliveira then read a resolution honoring them and presented them with a framed portrait of The Arts Center to them.

**A motion was made by Dr. Robles to adopt the resolution naming The Arts Center Box B “The Villarreal-Montemayor Family Box,” as presented. The motion was seconded by Mr. Gonzalez and carried unanimously. Exhibit “A”**

### **4. Board Briefing**

Dr. García called on Dr. Hilda Silva, Vice President for Student Affairs. Dr. Silva introduced Mr. Russell Harwood, Chess Program Director. Who gave a brief presentation on the success of the chess team at the Presidents Cup in Dallas.

### **5. Executive Session**

as provided by Government  
Code, Chapter 551.071-072

The Board considered two contracts and resolutions for purchase of real estate: Fort Brown Villas Condominium Unit 1004, Type B, Building 1, Phase I, Brownsville, Texas; and Fort Brown Villas Condominium Unit 1013, Type B, Building 1, Phase I, Brownsville, Texas.

**The Board convened in Executive Session at 5:25 p.m.**

**The Board reconvened in Regular Session at 6:08 p.m.**

**6. Consideration and possible action on matters discussed in Executive Session**

**Contract and resolution for purchase  
of Fort Brown Villas Condominium Unit 1004, Type B, Building 1,  
Phase I, Brownsville, Texas**

**A motion was made by Mr. Campirano to approve the earnest money contract and resolution for the acquisition of Fort Brown Villas Unit 1004, in the amount of \$35,000 as presented. The motion was seconded by Dr. Robles and carried unanimously. *Exhibit "B"***

**Contract and resolution for purchase  
of Fort Brown Villas Condominium Unit 1013, Type B, Building 1,  
Phase I, Brownsville, Texas**

**A motion was made by Mr. Campirano to approve the earnest money contract and resolution for the acquisition of Fort Brown Villas Unit 1013, in the amount of \$35,500 as presented. The motion was seconded by Ms. Garza and carried unanimously. *Exhibit "C"***

**7. Approval of Minutes of Previous Meeting**

**Consideration and possible action on  
Minutes of Regular Meeting on March 26, 2009**

**A motion was made by Ms. Garza to approve the Minutes of the Regular Meeting on March 26, 2009. The motion was seconded by Mr. Campirano and carried unanimously.**

**8. Resolution**

**Consideration and possible action on adopting a  
resolution in support of a grant application to the City of  
Brownsville Cultural Affairs Advisory Committee to partially  
underwrite the 2010 annual Brownsville  
Guitar Festival and Competition**

Mr. Oliveira called on Dr. David Pearson, Vice President for Partnership Affairs. Who provided a background on the Annual Brownsville Guitar Festival and Competition. That it has been held on our campus since 2002. He then introduced Dr. Michael Quantz of the Fine Arts Department the founder of the Festival, who described how the Festival provides training from the world's best guitarists, an opportunity for

students and their teachers to share ideas, master classes, and a series of artistic presentations. Dr. Michael Quantz is applying to the Brownsville Cultural Affairs Advisory Committee for \$25,000 to partially underwrite the cost of the Festival. If the application is successful, the funds will be used to underwrite travel and expenses of performers and judges, publicity and advertising as well as video recording. One of the grant requirements is approval of the application by the Board of Trustees.

**A motion was made by Dr. Robles to accept the resolution in support of a grant application to the City of Brownsville Cultural Affairs Advisory Committee to partially underwrite the 2010 annual Brownsville Guitar Festival and Competition in the amount of \$25,000. The motion was seconded by Ms. Garza and carried unanimously. Exhibit "D"**

## **9. Physical Facilities Committee**

### **Report**

#### **Consideration and possible action on Substantial Completion to JE Dunn/Terry Ray a Joint Venture for the construction of the REK Center**

Mr. Oliveira called on Chester Gonzalez to make the report. He reported that the Physical Facilities Committee did not meet as scheduled on Wednesday, April 22, 2009 and staff will present the items to the Board. He called on Ms. Veronica Mendez, Assistant Vice President for Planning and Construction, who reported that the Recreation, Education, and Kinesiology Center had achieved substantial completion. The facility included 108,891 sq. ft. a weight and fitness area, a full gymnasium, three basketball courts, two racquetball courts, two large multipurpose rooms, two medium classrooms, four small classrooms, one computer lab, two conference rooms, and fifteen faculty offices. Exterior work included a multipurpose field, a pool with six lanes, landscape surrounding the facility, and parking lot. Parsons 3DI from San Antonio was the Architect, and UT Systems Office of Facilities Planning and Construction served as the Project Manager. Substantial Completion inspection took place on March 26, 2009.

Mr. Oliveira called on Dr. David Pearson to make a presentation to Ms. Mendez for her work in successfully completing the first bond project building. Dr. Pearson gave an historical overview of the Sceptre. Mr. Oliveira then presented the Sceptre of the Scorpion to Ms. Mendez and thanked her for her hard work and leadership in bringing this project to completion.

**A motion was made by Mr. Gonzalez to accept Substantial Completion of the Recreation Education and Kinesiology Center and authorize the Assistant Vice President for Planning and Construction to close the**



**project upon completion of punch list items. The motion was seconded by Ms. Garza and carried unanimously. Exhibit "E"**

**Consideration and possible action on  
awarding a contract to purchase and install  
Theatrical Equipment for the Arts Center**

Ms. Mendez reported that requests for proposal for theatrical equipment were issued according to The University of Texas at Brownsville and Texas Southmost College policies for purchasing bids. The proposal amount of \$244,877 includes all equipment and labor for the facility.

**A motion was made by Mr. Gonzalez to negotiate a contract to install Theatrical Equipment for the Arts Center and authorize the Assistant Vice President for Planning and Construction to execute the contract. If unable to reach an agreement with Texas Scenic, Co., negotiations should then be entered into with the second highest ranked respondent, Secoa, Inc. The motion was seconded by Dr. Robles and carried unanimously. Exhibit "F"**

**10. Business Affairs Partnership Committee**

**Report**

Mr. Oliveira called on Mr. Campirano to provide the report. Mr. Campirano reported that the Business Affairs Partnership Committee met on April 16, 2009. They discussed and made recommendations on the following items:

**Consideration and possible action on  
approval of Budget Amendments for FY 2009**

Budget amendments #09-002 to #09-009 are necessary to adjust the expenses for fiscal agent fees for the arbitrage rebate calculations.

**A motion was made by Mr. Campirano to approve budget amendments #09-002, #09-003, #09-004, #09-005, #09-006, #09-007, #09-008, and #09-009 for Fiscal Year 2009 as presented. The motion was seconded by Dr. Robles and carried unanimously. Exhibit "G"**

**Consideration and possible action on  
approval of proposal for Annual Financial Audit**

Long and Chilton was selected to conduct the District's audit in April 2007. The contract was for one year with the option to renew for two additional years. Last year the District exercised its option to extend the contract for one year. Staff recommendation is to extend the contract for one additional year and go out for bids in Fiscal Year 2010.

**A motion was made by Mr. Campirano to select Long Chilton to conduct the District's audit for Fiscal Year 2008-2009 for \$32,235. The motion was seconded by Ms. Garza and carried unanimously. Exhibit "H"**

**Consideration and possible action on  
approval of Quote from PUB for overhead to  
underground utilities conversion**

In keeping with campus master plan values, this contract will to put utilities underground in front of the former Newman Center, which is being renovated as the new Campus Security Center for Campus Police.

**A motion was made by Mr. Campirano to award Brownsville Public Utilities Board the overhead to underground utilities conversion in the amount of \$40,029.46. The motion was seconded by Ms. Garza and carried unanimously. Exhibit "I"**

## **11. Student Affairs Partnership Committee**

### **Report**

Mr. Oliveira called on Ms. Garza to provide the report for the Student Affairs Partnership Committee that met on April 15, 2009.

Ms. Garza reported that Dr. Vince Solis, Associate Vice President, had provided the committee with presentations on student housing, athletics, and REK Center.

The student housing presentation was a follow-up to the previous Student Affairs Partnership Committee meeting, which had provided a more detailed version of our Student Housing program. Current student housing has 317 beds, and has for the past three years averaged 95% occupancy. Dr. Solis then presented a recommendation to increase Student Housing rates by 10% to meet repair needs and to increase safety for our students.

The proposed increase will:

- Result in a monthly increase of \$31.50, for a total monthly rent of \$346.50.
- Bring in approximately \$75,000 annually in additional funds.
- Increase security by hiring two security guards and upgrading the video surveillance system.

Dr. Solis's Scorpion Athletics presentation focused on the status of our Athletic program, including the staffing, budgets, and academic performance of student athletes.

The REK Center presentation brought the Committee up to date on the REK Center progress with an overview of the facility's site plan and programming. The REK Center will be shared by the Recreational Department and School of Education's Health and Human Performance Department.

## **12. Bond Projects**

Mr. Oliveira called on Dr. Pearson to make the report. Dr. Pearson reported that the Tax Bonds authorized by the voters in November 2004 call for a series of bond issuances up to a total of \$68 million. There have been four bond issuances: \$20 million in 2005, \$25 million in 2006, \$14 million in 2007, and \$5 million in 2008. The issuance this year would constitute the final limited tax bonds and maintenance tax notes issuance in the amount of \$4 million in limited tax bonds and \$3 million in the maintenance tax notes. Dr. Pearson introduced Anne Burger Entrekin, Senior Vice President with First Southwest Company in San Antonio, who gave a presentation on the market and upcoming bond sales.

**Consideration and possible action on Resolution  
authorizing the commencement of proceedings relating to  
the issuance of limited tax bonds, appointing district advisors  
and consultants; and other matters related thereto**

**A motion was made by Mr. Campirano to adopt a resolution authorizing the commencement of proceedings relating to the issuance of limited tax bonds, appointing district advisors and consultants; and other matters related thereto. The motion was seconded by Dr. Robles and carried unanimously. Exhibit "J"**

**Consideration and possible action on Resolution  
authorizing the commencement of proceedings relating to  
the issuance of maintenance tax notes, appointing district advisors  
and consultants; and other matters related thereto**

**A motion was made by Ms. Garza to adopt a resolution authorizing the commencement of proceedings relating to the issuance of maintenance**

**tax notes, appointing district advisors and consultants; and other matters related thereto. The motion was seconded by Mr. Campirano and carried unanimously. Exhibit "K"**

### **13. Second Quarter Financial Statement and Investment Report for FY 2009**

Mr. Oliveira called on Ms. Melba Sanchez, Assistant Vice President for Finance. Ms. Sanchez gave a report on the second quarter financial statement and investment report for fiscal year 2008-2009.

### **14. Construction Report**

*Dr. Pearson reported the following:*

- Renovations at the Campus Security Center ( former Newman Center) are 99% complete.
- Work continues at the Commissary Building. Many of the bricks have been repaired reversed and reinstalled, and much other work is being complete.
- Work on the Commandant's Quarters continues. The exterior is almost complete with detailing is a replicating that found on the original 1860's structure.
- Landscaping has begun at the Rusteberg paseo.
- A sidewalk from the Student Union to the REK Center is under construction to accommodate pedestrian traffic. Light poles are now installed.
- Renovation in the Cavalry building is now in progress.
- Work on the parking lot adjacent to the Amphitheatre is complete, and landscaping is in progress.
- The parking lot on 21<sup>st</sup> is in progress. This parking lot is an addition to an existing parking lot.
- Sabal palm preservation continues. The trees planted by the REK Center were donated by Dale Robinson and Melissa Avalos. A large oak tree was planted next to the Gym Annex, and a royal poinciana was planted in front of REK Center.

*Ms. Mendez reported the following:*

- Work continues at the New Library and Classroom buildings. Substantial completion is expected in May. The landscaping is in progress on the courtyard between the two buildings. The classrooms have received all the furniture and is ready for audio/visual installation.
- Work at the Center of Early Childhood Studies continues. Brick is being installed on the exterior of the administration building. The playground equipment has been installed.

- Work continues at the Arts Center. The project is on schedule to be completed at the end of the year.
- Work at the Science, Technology Learning Center building has begun.

## 15. President's Report

*Dr. García reported the following:*

- Student and community volunteers filed hundreds of free tax returns for Valley residents through the Volunteer Income Tax Assistance (VITA) program at UTB/TSC's International Technology, Education and Commerce Center.
- Families came out to support the UTB/TSC Fine Arts department during a day of fun at the Pirates and Music by the Bay fundraiser sponsored by Pirates Landing restaurant, the City of Port Isabel, SeaLife Center, Historic Trolley and El Paseo Arts Foundation.
- Area residents participated in the fourth annual Sgt. Keith A. Ferguson Memorial 5-K Walk/Run/Crawl to raise scholarship dollars for UTB/TSC Criminal Justice students.
- Three UTB/TSC chorale students placed in the top two in their divisions at the South Texas Region National Association of Teachers of Singing competition at Texas State University – San Marcos.
- Mrs. Garza, Dr. Pearson, and I attended the Association of Governing Board conference held in April 2009.
- The Brownsville Literacy Center announces its 11th annual "Symphony in the Park and All That Jazz" concert. The event will be held at Anniversary Plaza on the Student Union grounds of the University of Texas at Brownsville and Texas Southmost College on Saturday, April 25, 2009.
- Dr. Manuel G. Guajardo and John C. Hunter will be honored as UTB/TSC Distinguished Alumni in a ceremony on May 15, 2009.
- The 17th UTB/TSC commencement ceremony will be held at 8:00 a.m. on Saturday, May 16, 2009.
- The campus will be an early voting site for the upcoming City of Brownsville elections. The polls will be located in Mary Rose Cardenas North Hall Lobby from April 27-May 5, 2009. The polls are open from 8:30 a.m.-5:30 p.m. on weekdays, from 11am-4pm on Saturday, May 2, 2009, and will be closed on Sunday, May 3, 2009.

**16. Proposed Meeting Dates**

**Thursday, May 14, 2009**  
**Thursday, June 18, 2009**  
**July-No Meeting**  
**Thursday, August 27, 2009**  
**Thursday, September 17, 2009**

**Adjournment**

The meeting was adjourned by Chairman Oliveira at 8:35 p.m.

---

Mr. David G. Oliveira  
Chairman, Board of Trustees

---

Roberto Robles, M.D.  
Secretary, Board of Trustees

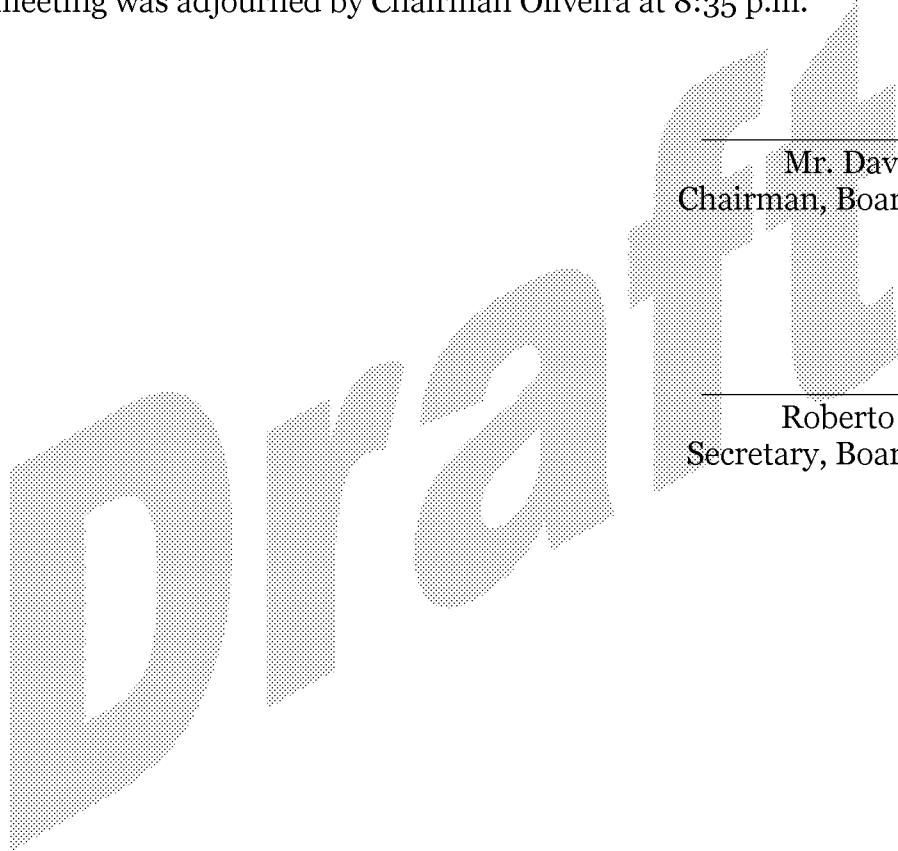

**NOTE:** The tape of the Regular Board of Trustees meeting held on March 26, 2009 is on file at the District Office of the Texas Southmost College District. The master tape is on file at the UTB/TSC Media center. These minutes were taken and transcribed by Max E. Roca, Administrative Secretary. Videotaping of the Board of Trustees' meetings began on April 11, 1996. They are aired on Channel KBSD in cooperation with the Brownsville Independent School District.



# TEXAS SOUTHMOST COLLEGE DISTRICT

## BOARD AGENDA REQUEST FORM

<b>Department/Division:</b> Office of Planning and Construction / Partnership Affairs.	<b>Board Meeting Date:</b> May 14, 2009
<b>Agenda Item:</b> Consideration and possible action on a contract for netting support system for the REK Center site	
<b>Rationale/Background:</b> As the REK Center project opens its doors to students, faculty and staff, a netting support system for the adjacent Scorpion baseball field is needed as a protective measure to the campus population and to prevent potential damage to the REK Center facility. The scope of work includes the design and installation of a netting support system along the perimeter of the Scorpion baseball field A request for proposals to design and install a netting support system was issued according to Texas Southmost College Board policies for purchasing bids. Proposals were received April 17, 2009 and were evaluated by an evaluation committee that included Mr. Doug Jowell, OFPC project manager, Ms. Laura Lara, OFPC senior project manager, Mr. Jacinto Cabrera, Construction Office Special Projects Coordinator and Ms. Patricia G. Sanchez, TSC Senior Buyer on April 20, 2009. A recommendation will be presented to the Texas Southmost College Board of Trustees Physical Facilities Committee at their meeting on May 7, 2009.	
<b>Recommended Action:</b> A recommendation will be coming from the Physical Facilities Committee to the Board of Trustees on May 14, 2009 to accept a contract to purchase and install a netting support system for the REK Center and authorize the Assistant Vice President for Planning and Construction to execute the contract.	
<b>Fiscal Implications:</b> REK Center Interest Earned	Budgeted Item: <input checked="" type="checkbox"/> Yes <input type="checkbox"/> No <input type="checkbox"/> N/A If no, explain:
<b>Attachments (List):</b> 1. Evaluation Committee recommendation 2. Evaluation Matrix 3. Bid Tabulation 4. Recommended Proposal	

<b>FOR OFFICE USE ONLY:</b>
<b>Board Action:</b> Approved: <input type="checkbox"/> Yes <input type="checkbox"/> No <input type="checkbox"/> N/A <input type="checkbox"/> Tabled for action on: _____
<b>Certified by:</b> _____ <b>Title:</b> _____ <b>Date:</b> _____



# Memorandum

---

**TO:** Ms. Veronica Mendez  
Assistant Vice President for Planning and Construction

**FROM:** Evaluation Committee  
Ms. Laura Lara, Mr. Doug Jowell, Mr. Jacinto Cabrera, Ms. Patricia Sanchez

**DATE:** May 5, 2009

**SUBJECT:** TSC RFP 09-11 Baseball Netting and Support System

---

Please accept this letter of recommendation from the evaluation committee to select **Net Connection, Inc.** from Birmingham, Alabama to supply and install the baseball netting and support system for the Scorpion Field of the UTB/TSC campus.

A request for proposal (RFP) was prepared by the Office for Planning and Construction calling for a list of general bidding requirements, specifications and scope of work for the baseball netting system. Specifications were prepared based on the need to prevent property damage and injuries to the campus population encompassing the Scorpion Field.

The Office for Planning and Construction solicited bids from qualified companies in accordance with TSC procurement policies. Advertisements were published on Wednesday, April 1, and Wednesday April 8, 2009. Proposals were received on April 17, 2009 from the following companies:

1. Net Connection
2. SpawGlass
3. Golf Range Netting
4. Net Services



Proposals have been carefully reviewed and evaluated by an evaluation committee that included: Ms. Laura Lara, OFPC Senior Project Manager, Mr. Doug Jowell, OFPC Resident Construction Manager; Mr. Jacinto Cabrera, Special Projects Coordinator and Ms. Patricia G. Sanchez, Senior Buyer.

The committee had checked inclusion of the required scope of work and specified material to perform these services. Based on the evaluation results, the committee determined that Net Connection, Inc. is the best qualified respondent to this RFP.

The best qualified respondent was determined based on the following criteria:

- a. Vendor's qualifications
- b. Past performance
- c. Warranty and service support
- d. Pricing

Net Connection, Inc. proposes to provide a team with 14 years experience in the industry with installations of similar systems along coastal regions within the state. The company also proposes to provide satisfactory warranties including two years in installation and five years pro-rated manufacturer's warranty.

In addition, Net Connection's proposal includes the most appropriate system option for the baseball field needs. This option includes the base proposal and alternate consisting on the installation of 300 Linear Feet (LF) and 240 LF, respectively, of galvanized steel support poles at a height of 40' above ground level and the associated netting system.

The Baseball Netting System provided by Net Connection provides for the following;

1. Based on industry trajectory studies, the 40' height system will meet the requirements in minimizing risk in the primary protection of pedestrians around the Scorpion Baseball field with some building protection.
2. The steel poles will be provided with a fusion bonded epoxy /weather resistant coating for corrosion protection.
3. Upon the issuance of a notice to proceed, a 4 to 6 week fabrication and mobilize period begins with an 8 day installation time frame.
4. Based on references provided, the company is knowledgeable in their product and industry. Their in house team's competence and familiarity with their system provides for greater efficiency and have conducted installations ahead of schedule. Their specified pole and netting systems have met their client's expectations.

Based on the evaluation results and research conducted, it is the recommendation of the committee to select **Net Connection, Inc.** as the supplier and installer of the baseball netting and support system for Scorpion Field, providing the 40' height pole system option for base proposal and alternate in the total amount of \$ 73,492.

**Texas Southmost College District**  
RFP Baseball Netting and Support System

Evaluation Matrix

Evaluation Team	NETConnection				NETServices			
	Vendor Qualifications	Past Performance	Warranty and Service Support	Pricing	Vendor Qualifications	Past Performance	Warranty and Service Support	Pricing
Evaluator 1	14.0	20.0	15.0	45.0	15.0	20.0	10.0	25.0
Evaluator 2	12.0	20.0	12.0	40.0	15.0	25.0	8.0	22.0
Evaluator 3	15.0	25.0	15.0	45.0	15.0	25.0	15.0	30.0
Evaluator 4	15.0	25.0	15.0	45.0	15.0	25.0	13.0	40.0
Score	56.0	90.0	57.0	175.0	60.0	95.0	46.0	117.0
Total Points	378.0				318.0			
Evaluation Team	Golf Range Netting				SpawGlass			
	Vendor Qualifications	Past Performance	Warranty and Service Support	Pricing	Vendor Qualifications	Past Performance	Warranty and Service Support	Pricing
Evaluator 1	15.0	20.0	15.0	20.0	8.0	15.0	0.0	30.0
Evaluator 2	10.0	20.0	15.0	20.0	10.0	10.0	0.0	30.0
Evaluator 3	12.0	23.0	0.0	30.0	14.0	24.0	15.0	35.0
Evaluator 4	15.0	25.0	15.0	35.0	10.0	20.0	10.0	40.0
Score	52.0	88.0	45.0	105.0	42.0	69.0	25.0	135.0
Total Points	290.0				271.0			

# Texas Southmost College District

RFP Baseball Netting and Support System

Proposal Tabulation

Advertisement dates: April 1 and 8, 2009

Bid Opening date: April 17, 2009 at 2:00 p.m.

	Bidders Name	40' Height Steel Poles		50' Height Steel Poles	
		Proposal Amount	Alternate	Proposal Amount	Alternate
1	Net Connection	\$ 50,944	\$ 22,548	\$ 59,697	\$ 27,897
2	SpawGlass	N/A	N/A	\$ 66,310	\$ 47,385
3	Golf Range Netting	N/A	N/A	\$ 92,400	\$ 71,000
4	NETServices	N/A	N/A	N/A	N/A

# **Net Connection**

## **SPORT AND GOLF NETTING**

**Texas Southmost College  
Baseball Netting and Support System**

### Table of Contents

	Pages
Cover Letter	
1) Criteria One: Qualifications	2
2) Criteria Two: References	2
3) Criteria Three: Warranty and Quality	3
Copy of Net Connection Warranty	
Letter from Redden Nets	
4) Criteria Four: Proposal Form (Exhibit C, D and E) And Attachment #1	14
5) Netting Specifications, and Detail	3

# **Net Connection**

## **SPORT AND GOLF NETTING**

April 15, 2009

Patricia G. Sanchez  
Senior Buyer  
Texas Southmost College  
Office for Planning and Construction  
1301 E. Madison St.  
Brownsville, Texas 78520

**Re:** Texas Southmost College  
Baseball Netting and Support System  
RFP No.: TSC RFP 09-11

Dear Patricia,

We are pleased to submit our response to the Request For Proposal for the Baseball Netting and Support System for the college. We are in receipt of Addendum #'s 1, 2, and 3. The scope of work and specifications listed for this project require a high level of expertise and require a certain skill set that will ensure that Texas Southmost College receives both a functional and high quality netting system that will protect both bystanders and adjoining property while not hindering the parks overall aesthetics. Net Connection, LLC not only will meet these necessary requirements for providing the highest quality netting system, but will exceed expectations with the level of service and efficiency in which we will handle your project. These attributes can be attested by the growing number of clients we have serviced across the country, as outlined in Criteria Two within the proposal.

The RFQ makes it clear that the respondents to the request must demonstrate the ability to design-build, engineer, and provide all materials, equipment, and labor necessary to complete a turnkey installation of the baseball netting system. It is our intent to clearly outline our approach and how each aspect of the project will be handled within this proposal. We have submitted several options, all of which we feel will provide a system that will meet the criteria laid out in the RFQ. We have provided options of varying heights as well as different support materials. It is our intention to offer the most cost effective options, while maintaining the integrity and overall intent of the netting system.

The final decision on choosing a company to provide this netting system comes down to your confidence that the respondent can perform to the level of standards set forth in the RFQ. Net Connection, LLC has a proven record of designing and installing projects such as this, and we are confident that this will be highlighted within this proposal.

Sincerely,



Andy Turner,  
Sales Manager

2637-A Queenstown Road  
Birmingham, AL 35210

1-877-818-0871  
[www.netconninc.com](http://www.netconninc.com)

# **Criteria Two – References and Past Performance**

# **Net Connection**

## **SPORT AND GOLF NETTING**

**Texas Southmost College  
Baseball Netting and Support System**

### Criteria One: Vendor's Qualifications

Net Connection, LLC  
2637-A Queenstown Road  
Birmingham, AL 35210

Established: 1999

Ownership: Bob Watson

#### Description:

Net Connection, LLC specializes in design and installation of netting systems. Our primary source of work revolves around netting systems and its support system. Our strength as a company is the ability to work with our customers, identifying their needs, and offering a comprehensive plan to meet their requirements in the most cost effective way for the customer. Our primary goal is to provide our customers with the highest quality netting system available that provides the containment and protection required at the most cost effective price.

#### Experience:

During the past fourteen years, we have provided our services in FL, AL, AK, NH, NJ, KS, GA, KY, NC, SC, VA, MI, MS, MO, MD, MT, OH, LA, PA, OK, OR, IL, IN, CO, NE, MN, TX, TN, UT, NY, Canada, and the Caribbean. We have provided and installed hundreds of netting systems to municipalities, colleges and universities, school systems, driving ranges, golf courses, learning centers, parks and recreation, and individuals. The following section outlines our key personnel that will be involved with this project and their past experience.

#### Key Personnel:

**Bob Watson- President, Owner**

- Retired from Detroit Edison, a public utility company in Michigan.
- Has over 30 years experience of power line utility installation and methods.
- Is a certified lineman.
- Has over 15 years of experience with design and installation of netting systems.
- Has expertise in wooden and steel poles as they relate to netting systems.
- Has either installed or overseen installation over 6.5 million square feet of netting throughout the country.
- Has been certified by Redden Nets as a qualified installer of their netting.

**Tom Pankey Jr.- Executive Vice President**

- Degree in Building Science from Auburn University
- Has over 20 years of experience in design/build construction projects.

2637-A Queenstown Road  
Birmingham, AL 35210

1-877-818-0871  
[www.netconninc.com](http://www.netconninc.com)

- Has overseen multiple complex building construction projects throughout the country.
- Has over 5 years experience with design and installation of netting systems.
- Has expertise in engineering aspects of wood and steel poles as they relate to netting systems.
- Has either installed or overseen installation of over 2.5 million square feet of netting systems throughout the country.
- Has expertise in building codes and ASCE standards.
- Has been certified by Redden Nets as a qualified installer of their netting.

**Andy Turner- Sales Manager**

- Degree in Agronomy and Soils from Auburn University.
- Has worked with multiple engineers in the Central and South Texas area on designing netting systems.
- Has either installed or overseen installation of over 1 million square feet of netting throughout the country.
- Has been certified by Redden Nets as a qualified installer of their netting.

**Bryan Capps- Lead Superintendent**

- Has over 7 years of experience in installation of netting systems.
- Has expertise in construction methods used in installation of netting systems.
- Is a certified operator of a digger derrick, aerial lifts, and other heavy equipment.
- Has safely constructed netting systems with no incidence for the entire tenure of employment.
- Has completed multiple safety classes for operating lifts and digging equipment.
- Has been certified by Redden Nets as a qualified installer of their netting.



# **Net Connection**

## **SPORT AND GOLF NETTING**

**Texas Southmost College**  
**Baseball Netting and Support System**

### Criteria Two: References and Past Performance

The following projects were performed entirely by Net Connection, LLC. They are relevant to this project in that they are located in unusual and high wind zones and all are used as both a protective and barrier netting system. Each project listed shows our ability to design and install a turnkey netting system for owners that have similar criteria as Texas Southmost College.

#### **Shoreline Park- Baseball and Softball Fields**

800 Shoreline Drive  
Gulf Breeze, FL 32562  
**Contact:** Ron Pulley  
**Phone:** 850-934-5140  
**Contract Amount:** \$89,996.00

#### **Description:**

Designed and Installed protective and barrier netting around multiple baseball and softball fields. Netting was installed upon 34 steel poles. Support system was designed for 140mph, exposure C wind zone. The overall height of the netting varies between 28' AGL and 32' AGL. Relationship with customer for 2 years.

#### **Oakbourne Country Club**

3700 E. Simcoe Street  
Lafayette, LA 70501  
**Contact:** Steve Chatelain  
**Phone:** 337-235-6426 ext. 211  
**Contract Amount:** \$438,814.00

#### **Description:**

Designed and Installed protective and barrier netting alongside the driving range of Golf Course. Overall dimensions of netting system are 120' AGL by 650lf. Netting system was designed for 120mph, exposure B wind zone. Netting was installed upon 24" steel poles. The project scope included stamped engineered drawings. Relationship since September 2007.

**Texas Southmost College  
Baseball Netting and Support System**

**University of Michigan**

1000 S. State Street  
Ann Arbor, MI 48109

**Contact:** Rod Rademacher

**Phone:** 734-647-9763

**Contract Amount:** > \$290,000.00 (multiple contracts)

**Description:**

Design and Install multiple netting projects which include soccer barrier netting with steel support poles, driving range netting system on wood poles, barrier netting systems within golf course on steel and wood poles, protective netting along baseball field using #18 Redden Netting, field hockey netting, provide design work for future netting systems. Have had ongoing relationship since 1994.

**Corpus Christi Independent School District**

1220 Agnes Street  
Corpus Christi, TX 78401

**Contact:** Engineer- Paul Pylarczyk, PE Naismith Engineering

**Phone:** 361-814-9900

Senior Buyer- Arnulfo Gonzalez, Corpus Christi ISD

**Phone:** 361-886-9100

**Contract Amount:** \$59,150.00

**Description:**

Assisted in design of netting system and installed a new netting system to existing wooden poles to four (4) baseball stadiums within the school district. Netting was at various heights up to 50' AGL. Netting is located within a 120 mph wind zone. Systems were placed along foul lines and behind backstops as both protective and barrier systems.

**Vestavia Country Club**

400 Beaumont Road  
Vestavia Hills, AL

**Contact:** Allen Austin, Director of Golf

**Phone:** 205-822-8300

**Contract Amount:** \$39,510.00

**Description:**

Replaced 600 LF of 25' high netting with 50' high netting along the left side of the driving range. New netting was installed on wood poles. At a low point in the line of netting we had to design in a six foot tall netting skirt to allow for easy runoff during high rain and flooding conditions. The system has worked flawlessly. Relationship with customer since 2003.

# **Criteria Three – Warranty and Service Support Program**

# **Net Connection**

## **SPORT AND GOLF NETTING**

**Texas Southmost College  
Baseball Netting and Support System**

### Criteria Three: Warranty and Service Support Program

**Quality...it's our Motto.** It is our firm belief that poorly installed and/or inferior quality netting is aesthetically unpleasant and requires continuous repair and maintenance. Any initial savings are soon lost to these repairs. In addition, there may be liability concerns when netting is in a state of disrepair. Our philosophy is to provide the highest **quality** netting systems, which in the long run at by far the most cost effective. Since we provide our services throughout the country, it is imperative that our design and construction are done with the highest level of workmanship and the use of the highest **quality** materials for our customers. Our reputation is our most important asset, because in this industry, the vast majority of work comes from referrals from existing customers and word of mouth.

#### **Warranty:**

Net Connection, LLC provides a two year installation warranty. This covers all aspects of the installation of the netting system. This assures our customers that each component of the support system and the netting are done with expert craftsmanship and care the first time. In the last 14 years, we have never had a customer make a claim because of faulty installation or premature failure due to improper installation.

Our proposal also includes a five year pro-rated manufacturer's warranty. This covers any defects or failures within the netting caused by normal conditions within this time period. Redden Nets constructs their baseball netting with the highest quality nylon that is available. Each net is custom made to fit the exact dimensions for the netting system. (see attached specification sheet for the proposed netting to be used on this project)

#### **Quality Assurance:**

After each netting project that we complete, we send our customers a survey asking them to rank their experience in five main categories. The categories are service, price, sales team, final product, and construction team. 100% of the customers that responded rated their experience as either "satisfied" or "very satisfied". This is a testament to the measure we take in the beginning stages of project to ensure that we are providing a quality product that meets your needs. We use only the highest quality of materials in both the support system and the netting. We intend to keep an open line of communication with our customers throughout the entire project and inform you the progress and status of each stage of your project. Net Connection, LLC makes a point to leave the project with the customer completely happy and have a full understanding on how the netting system will function. We feel we have provided a quality product when the end product is functioning in the capacity that it is intended, the customer is happy with the end product, and that the netting system will provide the protection intended for its life expectancy and beyond.

# Net Connection

SPORT AND GOLF NETTING

## Netting System Installation Warranty

Net Connection, Inc. warrants that the netting system installation will be free from defects for a two-year period from the date of completion. The warranty covers the following items:

- **Hardware;** any hardware that proves to be defective during the warranty period, will be replaced at no cost to the customer
- **Cable;** any cable that proves to be defective during the warranty period will be replaced at no cost to the customer
- **Poles;** any poles that prove to be defective during the warranty period, will be replaced at no cost to the customer.
- **Workmanship;** any defects due to poor workmanship during the installation process, will be corrected at no cost to the customer.
- **Netting;** the netting is covered under a warranty from the manufacturer.

Net Connection's sole obligation and the Customer's sole remedy, if the warranty is breached, is to re-perform such services as are defective if the Customer gives written notice to Net Connection, Inc. within seven days of discovery of said defect and if the defect occurs within two years from the date the Services were performed.

The warranty does not apply to damage caused by the following:

- Acts of vandalism
- Winds in excess of design criteria
- Customer misuse
- Equipment, i.e. ball pickers, mower decks, golf carts, etc.
- Acts of God, i.e. tornados, hurricanes, ice storms, heavy snow, lightening, fire, etc.
- Acts of war

The warranty period for any re-performed Services shall extend only to the end of the original warranty period and after that period all liability of Net Connection, Inc. shall cease.

Customer: \_\_\_\_\_ Address \_\_\_\_\_

Date of Installation: \_\_\_\_\_

Net Connection, Inc. Representative: \_\_\_\_\_

Printed Name: \_\_\_\_\_

Title: \_\_\_\_\_



Practical Solutions for Recreational and Industrial Netting Applications

Texas Southmost College  
Office For Planning and Construction  
Senior Buyer  
Brownsville, TX 78520

Attn: Ms. Patricia G. Sanchez

Dear Ms. Sanchez,

As the exclusive netting supplier for Net Connection, LLC for the past 12+ years, we have provided custom netting for sports, environmental and industrial projects. Bob Watson, from our observation, leads a crew of several employees in pole setting, mounting hardware and installing netting systems ranging from 20 to 160 feet above ground level. I have personally observed finished netting projects and can attest to the quality and care of their workmanship.

Net Connection has installed our custom built netting systems utilizing our proven method of internal rope supports called riblines. The rope support is hand sewn into the netting panels to help distribute the weight evenly throughout the length of the panels.

Redden Nets is very particular about how our nets are installed and who installs them. You will not find a company that does a better job or one that we trust more than Net Connection. Please contact me with any questions or if you wish to discuss your project in further detail.

Sincerely,

Ron Chiabai  
Division Manager  
Redden Nets  
4/14/09

**A Division of Redden Marine Supply, Inc.**

1411 Roeder Avenue Bellingham, WA 98225-2916 / 360•733•0250 800•426•9284 / FAX 360•733•7180 / [www.reddeninc.com](http://www.reddeninc.com)

**Criteria Four – Proposal Form  
(Exhibit C, D, and E) and  
Attachment #1**

EXHIBIT C

**PRICING PROPOSAL FORM**

To: Texas Southmost College  
Office for Planning and Construction  
Brownsville, Texas 78520

**Baseball Netting and Support System**

Proposals are due: Thursday, April 16, 2009 at 2:00 PM at the TSC Office for Planning and Construction, 1301 E. Madison, Lucena House; Brownsville, TX 78520.

Note: Mark outside of envelope:

Proposal For: Baseball Netting and Support System (title of project)

I have received the documents titled Baseball Netting and Support System  
(title of project) and drawings dated 04 / 01 / 09

I have received Addenda No. (s) 1, 2 & 3, and I have included their provisions in my bid. I have examined both the documents and the site.

In submitting this bid, I agree:

1. To hold price open for a period of ninety (90) days after the Proposal Opening date.
2. To accept the provisions of the Instructions to Bidders regarding dispositions of the Bid Security.
3. To enter into and execute a Contract with the Texas Southmost College, if awarded on the basis of the Proposal, and to furnish Bonds if required, in accordance with the owners requirements and Instructions to Bidders.
4. To accomplish the work in accordance with the Specifications and Drawings provided
5. To complete the work within forty five (45) calendar days after receiving Notice of Award.

In compliance with the above, I propose to perform all work required for the described project scope of work as follows:



EXHIBIT C

Section 1 (refer to Exhibit B)	
Description	Cost
Material	\$
Labor	
Installation	
Other (not listed) Specify:	In an effort to provide the owner with several options, we are unable to use this form. Please refer to Attachment One.
Subtotal	\$
10 % *Contingency	\$
Total Amount	\$

\*Contingency amount is for owner's use only. It cannot be used without owner's approval.

**ALTERNATE #1**

Section 2 (refer to Exhibit B)	
Description	Cost
Material	\$
Labor	
Installation	
Other (not listed) Specify:	see Note Above
Total Amount	\$

In submitting this proposal, I certify that Net Connection, LLC (name of firm) has not been found guilty in a judicial or state administrative agency proceeding for unfair business practices within the year preceding the date of this statement. I further

EXHIBIT C

certify that no officer of Net Connection, LLC (name of firm) has served, within the past years as an officer of another company which has been found guilty in a judicial or state administrative agency proceeding of unfair business practice.

Respectfully submitted,

  
By: Signature and Title

President

April 16, 2009  
Date

Net Connection, LLC  
Firm

2037-A Queenstown Rd  
Address

Birmingham  
City

AL 35210  
State

205-838-2995  
Phone Number

# **Net Connection**

## **SPORT AND GOLF NETTING**

**Project Bid 09069**  
**RFP No.: TSC RFP09-11**  
**Attachment #1**

**April 15, 2009**

**Customer: Texas Southmost College**

**Location: Baseball Field**

### **PROJECT SCOPE**

Provide all labor, materials and equipment necessary for installation of netting system to locations around baseball field. This proposal is in response to the RFP09-11 and is bid according to the information provided within the RFP, along with Addendum's #1,#2 and #3. This proposal is split up into two sections (as requested on Exhibit B in addendum #2). The first section is for a netting system to be installed along the left outfield fence, approx. 300LF, and the second section is an alternate for a netting system to be installed along the 3<sup>rd</sup> baseline, approx. 240LF. Included in this proposal are four (4) options per section. Two options are for installing the netting using steel poles and two options installing the netting using wooden poles. Each section has an option for a 40' high system and an option for a 50' high system. All options have been designed to meet the loading criteria for these heights within a 120 MPH exposure B wind zone. All foundations for the support poles were designed per the loading requirements and the soil conditions that were outlined in the Geotechnical Report added in Addendum #3.

It is our opinion that a netting height of 40' to 50' will be sufficient to contain the vast majority of the balls. This is based on our experience with other projects of similar nature.

## **Section 1**

### **Option 1A- 40'Tall Netting on Wooden Poles**

This option includes installing a 300 LF netting system on wooden support poles at an overall height of 40' above ground level

**Furnish and Install** the following:

- Six, Class 1, 50' pressure treated wood poles.
- 12,000 sq. ft. of **Redden # 18 DuPont type 66 high grade nylon netting**, including rope border and interior riblines. Netting includes a five-year pro-rated manufacture's warranty
- 1,500' of 5/16" extra high strength galvanized steel stand support cable.
- 650 ea. 9/32" cadmium plated steel attachment snaps (cadmium offers superior corrosion protection against galvanized or nickel plated).
- All supporting bolts, washers, clamps, and other hardware which all conform to the specifications of one or more of the following: **ANSI, ASTM, IEEE, NEMA**
- All labor and equipment charges included.

<b>Option 1A Cost</b> .....	<b>\$ 31,582.00</b>
<b>Contingency (10%)</b> .....	<b>\$ 3,158.20</b>
<b>Option 1A Total Cost</b> .....	<b>\$ 34,740.20</b>

### **Option 2A- 50'Tall Netting on Wooden Poles**

This option includes installing a 300 LF netting system on wooden support poles at an overall height of 50' above ground level

**Furnish and Install** the following:

- Seven, Class 1, 60' pressure treated wood poles.
- 15,000 sq. ft. of **Redden # 18 DuPont type 66 high grade nylon netting**, including rope border and interior riblines. Netting includes a five-year pro-rated manufacture's warranty
- 1,600' of 5/16" extra high strength galvanized steel stand support cable.
- 700 ea. 9/32" cadmium plated steel attachment snaps (cadmium offers superior corrosion protection against galvanized or nickel plated).
- All supporting bolts, washers, clamps, and other hardware which all conform to the specifications of one or more of the following: **ANSI, ASTM, IEEE, NEMA**
- All labor and equipment charges included.

<b>Option 2A Cost</b> .....	<b>\$ 34,850.00</b>
<b>Contingency (10%)</b> .....	<b>\$ 3,485.00</b>
<b>Option 2A Total Cost</b> .....	<b>\$ 38,335.00</b>

### Option 3A- 40'Tall Netting on Steel Poles

This option includes installing a 300 LF netting system on steel support poles at an overall height of 40' above ground level.

#### Furnish and Install the following:

- Six, 12.75" O.D. steel support poles. Poles are FBE coated to offer excellent corrosion resistance when embedded in corrosive soils. Poles will be painted with a zinc chromate iron oxide primer and two coats of black enamel paint.
- 12,000 sq. ft. of **Redden # 18 DuPont type 66 high grade nylon netting**, including rope border and interior riblines. Netting includes a five-year pro-rated manufacture's warranty
- 1,500' of 5/16" extra high strength galvanized steel stand support cable.
- 650 ea. 9/32" cadmium plated steel attachment snaps (cadmium offers superior corrosion protection against galvanized or nickel plated).
- All supporting bolts, washers, clamps, and other hardware which all conform to the specifications of one or more of the following: **ANSI, ASTM, IEEE, NEMA**
- All labor and equipment charges included.

<b>Option 3A Cost</b> .....	<b>\$ 46,313.00</b>
<b>Contingency (10%)</b> .....	<b>\$4,631.30</b>
<b>Option 3A Total Cost</b> .....	<b>\$50,944.30</b>

### Option 4A- 50'Tall Netting on Steel Poles

This option includes installing a 300 LF netting system on steel support poles at an overall height of 50' above ground level

#### Furnish and Install the following:

- Six, 16" O.D. steel support poles. Poles will be painted with a zinc chromate iron oxide primer and two coats of black enamel paint.
- 15,000 sq. ft. of **Redden # 18 DuPont type 66 high grade nylon netting**, including rope border and interior riblines. Netting includes a five-year pro-rated manufacture's warranty
- 1,600' of 5/16" extra high strength galvanized steel stand support cable.
- 700 ea. 9/32" cadmium plated steel attachment snaps (cadmium offers superior corrosion protection against galvanized or nickel plated).
- All supporting bolts, washers, clamps, and other hardware which all conform to the specifications of one or more of the following: **ANSI, ASTM, IEEE, NEMA**
- All labor and equipment charges included.

<b>Option 4A Cost</b> .....	<b>\$ 54,270.00</b>
<b>Contingency (10%)</b> .....	<b>\$ 5,427.00</b>
<b>Option 4A Total Cost</b> .....	<b>\$59,697.00</b>

**Section 2**

**Option 1B- 40'Tall Netting on Wooden Poles**

This option includes installing a 240 LF netting system on wooden support poles at an overall height of 40' above ground level

**Furnish and Install** the following:

- Five, Class 1, 50' pressure treated wooden poles.
- 9,600 sq. ft. of **Redden # 18 DuPont type 66 high grade nylon netting**, including rope border and interior riblines. Netting includes a five-year pro-rated manufacture's warranty
- 1,000 lf of 5/16" extra high strength galvanized steel stand support cable.
- 450 ea. 9/32" cadmium plated steel attachment snaps (cadmium offers superior corrosion protection against galvanized or nickel plated).
- All supporting bolts, washers, clamps, and other hardware which all conform to the specifications of one or more of the following: **ANSI, ASTM, IEEE, NEMA**
- All labor and equipment charges included.

**Option 1B Cost..... \$ 11,842.00**

**Option 2B- 50'Tall Netting on Wooden Poles**

This option includes installing a 240 LF netting system on wooden support poles at an overall height of 50' above ground level

**Furnish and Install** the following:

- Six, Class 1, 60' pressure treated wooden poles.
- 12,000 sq. ft. of **Redden # 18 DuPont type 66 high grade nylon netting**, including rope border and interior riblines. Netting includes a five-year pro-rated manufacture's warranty
- 1,100' of 5/16" extra high strength galvanized steel stand support cable.
- 475 ea. 9/32" cadmium plated steel attachment snaps (cadmium offers superior corrosion protection against galvanized or nickel plated).
- All supporting bolts, washers, clamps, and other hardware which all conform to the specifications of one or more of the following: **ANSI, ASTM, IEEE, NEMA**
- All labor and equipment charges included.

**Option 2B Cost..... \$ 13,345.00**

### Option 3B- 40'Tall Netting on Steel Poles

This option includes installing a 240 LF netting system on steel support poles at an overall height of 40' above ground level

**Furnish and Install** the following:

- Six, 12.75" O.D. steel support poles. Poles are FBE coated to offer excellent corrosion resistance when embedded in corrosive soils. Poles will be painted with a zinc chromate iron oxide primer and two coats of black enamel paint.
- 9,600 sq. ft. of **Redden # 18 DuPont type 66 high grade nylon netting**, including rope border and interior riblines. Netting includes a five-year pro-rated manufacture's warranty
- 1,000 lf of 5/16" extra high strength galvanized steel stand support cable.
- 500 ea. 9/32" cadmium plated steel attachment snaps (cadmium offers superior corrosion protection against galvanized or nickel plated).
- All supporting bolts, washers, clamps, and other hardware which all conform to the specifications of one or more of the following: **ANSI, ASTM, IEEE, NEMA**
- All labor and equipment charges included.

**Option 3B Cost**..... \$ 22,548.00

### Option 4B- 50'Tall Netting on Steel Poles

This option includes installing a 240 LF netting system on steel support poles at an overall height of 50' above ground level

**Furnish and Install** the following:

- Six, 16" O.D. steel support poles. Poles will be painted with a zinc chromate iron oxide primer and two coats of black enamel paint.
- 12,000 sq. ft. of **Redden # 18 DuPont type 66 high grade nylon netting**, including rope border and interior riblines. Netting includes a five-year pro-rated manufacture's warranty
- 1,100 lf of 5/16" extra high strength galvanized steel stand support cable.
- 500 ea. 9/32" cadmium plated steel attachment snaps (cadmium offers superior corrosion protection against galvanized or nickel plated).
- All supporting bolts, washers, clamps, and other hardware which all conform to the specifications of one or more of the following: **ANSI, ASTM, IEEE, NEMA**
- All labor and equipment charges included.

**Option 4B Cost**..... \$ 27,897.00

Clarifications & Exclusions:

- Proposal is based on clear access to site for required equipment; and excludes the repair of any damage to the site required to access or install the system.
- Proposal includes the use of guying on all end conditions of netting system. If guying is not acceptable, wooden poles will not be allowed for this project and an adjustment in price will be necessary to resize the steel poles.
- Excludes any and all sales and use taxes.
- No permits or license are required for this project per City of Brownsville office of Permitting and Inspections.
- Proposal includes a site visit prior to start of construction of netting system.
- Proposal includes stamped engineered drawings by Engineer licensed in State of Texas and the cost associated.
- Per our conversation with an appointed Windstorm Engineer in Brownsville, it appears that this type of project will not be approved for certification in the Windstorm Program of the Texas State Insurance. However, a contingency has been added to the proposal to cover any costs associated with obtaining an approved engineer to certify netting system for Windstorm Program in the event that this project will be covered. If this is not to be required, a reduction in the price can be given.
- All Section Two option prices assume that the work will be awarded and constructed in conjunction with the Section One option.
- Excludes cost of performance and payment bond as per requirements within TSC RFP09-11.
- Excludes erosion Control Plan, including any silt fence or other devices that may be required by the governing authority.
- Excludes disposal of spoil materials from excavation.
- The net is removable, therefore the poles have not been sized to carry ice or snow loads.

Digging Clause: This bid is conditional on suitable subsoil conditions. Any and all additional expenses as a result of **rock drilling, boring, blasting, steel casings, de-watering or soil stabilization** will result in additional charges.

**Prices quoted in effect for 30 days**



## EXHIBIT D

### EXECUTION OF OFFER

**THIS EXECUTION OF OFFER MUST BE COMPLETED, SIGNED AND RETURNED WITH PROPOSER'S PROPOSAL. FAILURE TO COMPLETE, SIGN AND RETURN THIS EXECUTION OF OFFER WITH THE PROPOSER'S PROPOSAL MAY RESULT IN THE REJECTION OF THE PROPOSAL.**

- 2.1 By signature hereon, Proposer represents and warrants the following:
- 2.1.1 Proposer acknowledges and agrees that (1) this RFP is a solicitation for a proposal and is not a contract or an offer to contract; (2) the submission of a proposal by Proposer in response to this RFP will not create a contract between Texas Southmost College (TSC) and Proposer; (3) College has made no representation or warranty, written or oral, that one or more contracts with College will be awarded under this RFP; and (4) Proposer will bear, as its sole risk and responsibility, any cost arising from Proposer's preparation of a response to this RFP.
  - 2.1.2 Proposer is a reputable company that is lawfully and regularly engaged in providing the Services.
  - 2.1.3 Proposer has the necessary experience, knowledge, abilities, skills, and resources to perform the Services.
  - 2.1.4 Proposer is aware of, is fully informed about, and is in full compliance with all applicable federal, state and local laws, rules, regulations and ordinances.
  - 2.1.5 Proposer understands (i) the requirements and specifications set forth in this RFP and (ii) the terms and conditions set forth in the Agreement under which Proposer will be required to operate.
  - 2.1.6 If selected by TSC, Proposer will not delegate any of its duties or responsibilities under this RFP or the Agreement to any sub-contractor, except as expressly provided in the Agreement.
  - 2.1.7 If selected by TSC, Proposer will maintain any insurance coverage as required by the Agreement during the term thereof.
  - 2.1.8 All statements, information and representations prepared and submitted in response to this RFP are current, complete, true and accurate. Proposer acknowledges that College will rely on such statements, information and representations in selecting the Contractor. If selected by the College, Proposer will notify College immediately of any material change in any matters with regard to which Proposer has made a statement or representation or provided information.
  - 2.1.9 PROPOSER WILL DEFEND WITH COUNSEL APPROVED BY TSC, INDEMNIFY, AND HOLD HARMLESS, THE COLLEGE, THE STATE OF TEXAS, AND ALL OF THEIR REGENTS, OFFICERS, AGENTS AND EMPLOYEES, FROM AND AGAINST ALL ACTIONS, SUITS, DEMANDS, COSTS, DAMAGES, LIABILITIES AND OTHER CLAIMS OF ANY NATURE, KIND OR DESCRIPTION, INCLUDING REASONABLE ATTORNEYS' FEES INCURRED IN INVESTIGATING, DEFENDING OR SETTLING ANY OF THE FOREGOING, ARISING OUT OF, CONNECTED WITH, OR RESULTING FROM ANY NEGLIGENT ACTS OR OMISSIONS OR WILLFUL MISCONDUCT OF PROPOSER OR ANY AGENT, EMPLOYEE, SUBCONTRACTOR, OR SUPPLIER OF PROPOSER IN THE EXECUTION OR PERFORMANCE OF ANY CONTRACT OR AGREEMENT RESULTING FROM THIS RFP.
  - 2.1.10 Pursuant to Sections 2107.008 and 2252.903, *Government Code*, any payments owing to Proposer under any contract or agreement resulting from this RFP may be applied directly to any debt or delinquency that Proposer owes the State of Texas or any agency of the State of Texas regardless of when it arises, until such debt or delinquency is paid in full.
- 2.2 By signature hereon, Proposer offers and agrees to furnish the Services to College and comply with all terms, conditions, requirements and specifications set forth in this RFP.
- 2.3 By signature hereon, Proposer affirms that it has not given or offered to give, nor does Proposer intend to give at any time hereafter, any economic opportunity, future employment, gift, loan, gratuity, special discount, trip, favor or service to a public servant in connection with its submitted proposal. Failure to sign this Execution of Offer, or signing with a false statement, may void the submitted proposal or any resulting contracts, and the Proposer may be removed from all proposal lists at University.
- 2.4 By signature hereon, Proposer certifies that it is not currently delinquent in the payment of any taxes due under Chapter 171, *Tax Code*, or that Proposer is exempt from the payment of those taxes, or that Proposer is an out-of-state taxable entity that is not subject to those taxes, whichever is applicable. A false certification will be deemed a material breach of any resulting contract or agreement and, at University's option, may result in termination of any resulting contract or agreement.
- 2.5 By signature hereon, Proposer hereby certifies that neither Proposer nor any firm, corporation, partnership or institution represented by Proposer, or anyone acting for such firm, corporation or institution, has violated the antitrust laws of the State of Texas, codified in Section 15.01, et seq., *Business and Commerce Code*, or the Federal antitrust laws, nor communicated directly or indirectly the proposal made to any competitor or any other person engaged in such line of business.

EXHIBIT D

2.6 By signature hereon, Proposer certifies that the individual signing this document and the documents made a part of this RFP, is authorized to sign such documents on behalf of Proposer and to bind Proposer under any agreements and other contractual arrangements that may result from the submission of Proposer's proposal.

2.7 By signature hereon, Proposer certifies as follows:

"Under Section 231.006, *Family Code*, relating to child support, Proposer certifies that the individual or business entity named in the Proposer's proposal is not ineligible to receive the specified contract award and acknowledges that any agreements or other contractual arrangements resulting from this RFP may be terminated if this certification is inaccurate."

2.8 By signature hereon, Proposer certifies that (i) no relationship, whether by blood, marriage, business association, capital funding agreement or by any other such kinship or connection exists between the owner of any Proposer that is a sole proprietorship, the officers or directors of any Proposer that is a corporation, the partners of any Proposer that is a partnership, the joint venturers of any Proposer that is a joint venture or the members or managers of any Proposer that is a limited liability company, on one hand, and an employee of any component of The College, on the other hand, other than the relationships which have been previously disclosed to College in writing and (ii) Proposer has not been an employee of any component institution of TSC within the immediate twelve (12) months prior to the Submittal Deadline. All disclosures by Proposer in connection with this certification will be subject to administrative review and approval before College enters into a contract or agreement with Proposer.

2.9 By signature hereon, Proposer certifies that in accordance with Section 2155.004, *Government Code*, no compensation has been received for its participation in the preparation of the requirements or specifications for this RFP. In addition, Proposer certifies that an award of a contract to Proposer will not violate Section 2155.006, *Government Code*, prohibiting College from entering into a contract that involves financial participation by a person who, during the previous five years, has been convicted of violating federal law or assessed a penalty in a federal civil or administrative enforcement action in connection with a contract awarded by the federal government for relief, recovery, or reconstruction efforts as a result of Hurricane Rita, Hurricane Katrina, or any other disaster occurring after September 24, 2005. Pursuant to Sections 2155.004 and 2155.006, *Government Code*, Proposer certifies that Proposer is not ineligible to receive the award of or payments under the Agreement and acknowledges that the Agreement may be terminated and payment withheld if these certifications are inaccurate.

2.10 By signature hereon, Proposer certifies its compliance with all federal laws and regulations pertaining to Equal Employment Opportunities and Affirmative Action.

2.11 By signature hereon, Proposer represents and warrants that all products and services offered to College in response to this RFP meet or exceed the safety standards established and promulgated under the Federal Occupational Safety and Health Law (Public Law 91-596) and the *Texas Hazard Communication Act*, Chapter 502, *Health and Safety Code*, and all related regulations in effect or proposed as of the date of this RFP.

2.12 Proposer will and has disclosed, as part of its proposal, any exceptions to the certifications stated in this Execution of Offer. All such disclosures will be subject to administrative review and approval prior to the time College makes an award or enters into any contract or agreement with Proposer.

2.13 **Proposer should complete the following information:**

If Proposer is a Corporation, then State of Incorporation: \_\_\_\_\_

If Proposer is a Corporation then Proposer's Corporate Charter Number: \_\_\_\_\_

RFP No.: 09-11

EXHIBIT D

**NOTICE:** WITH FEW EXCEPTIONS, INDIVIDUALS ARE ENTITLED ON REQUEST TO BE INFORMED ABOUT THE INFORMATION THAT GOVERNMENTAL BODIES OF THE STATE OF TEXAS COLLECT ABOUT SUCH INDIVIDUALS. UNDER SECTIONS 552.021 AND 552.023, GOVERNMENT CODE, INDIVIDUALS ARE ENTITLED TO RECEIVE AND REVIEW SUCH INFORMATION. UNDER SECTION 559.004, GOVERNMENT CODE, INDIVIDUALS ARE ENTITLED TO HAVE GOVERNMENTAL BODIES OF THE STATE OF TEXAS CORRECT INFORMATION ABOUT SUCH INDIVIDUALS THAT IS INCORRECT.

Submitted and Certified By:

Net Connection, LLC  
(Proposer Institution's Name)

  
(Signature of Duly Authorized Representative)

Bob Watson, President  
(Printed Name/Title)

April 16, 2009  
(Date Signed)

2637 Queenstown Rd Suite A  
(Proposer's Street Address)

Birmingham, AL 35210  
(City, State, Zip Code)

205-838-2995  
(Telephone Number)

205-838-2997  
(FAX Number)



## EXHIBIT E

# TERMS AND CONDITIONS

### 1. BID REQUIREMENTS:

- 1.1 Submit Bid Invitation on this form. Each bid shall be placed in a separate envelope and properly identified with Bid Invitation No. and Opening Date. Bids must be time-stamped at Texas Southmost College, Lucena Building, 1301 E. Madison St., Brownsville, TX 78520 on or before opening date and time shown on other side of this form. Late bids will not be considered.
- 1.2 Bids should be quoted F.O.B. Destination. If otherwise, bidder will show exact cost to deliver. Bid unit price on the quantity specified, extend and show total. In case of errors, unit prices shall govern. Bid prices will be considered firm for acceptance within 90 days after the bid opening date unless otherwise specified. Cash discounts will not be considered in determining award; all cash discounts offered will be taken if earned. Bidder will list and deduct all trade discounts, educational discounts, and other discounts, not based on early payment from the bidder's prices quoted.
- 1.3 College is exempt from State Sales Tax and Federal Excise Tax. Do not include in bid. Tax Exemption Certificate furnished upon request.
- 1.4 Bids must give full name and address of bidder.
- 1.5 College reserves the right to accept or reject all or part of any bid, waive any formalities or technical inconsistencies, delete any requirement or specification from this invitation, or terminate this solicitation when deemed to be in college's best interest.
- 1.6 Facsimile bids, telephone bids and/or email bids are not acceptable in response to this Invitation UNLESS BID OPENING DATE SPECIFIES "RETURN MAIL". Email responses to bids NOT MARKED WITH A BID OPENING DATE OF "RETURN MAIL" WILL BE DELETED WITHOUT REVIEW AND WILL NOT BE CONSIDERED AS VALID RESPONSES. CAUTION: College offers facsimile service as a convenience only. College shall not be responsible for bids received late, illegible, incomplete, or otherwise non responsive due to failure of electronic equipment or operator error. Confirmation of facsimile bids is not required.
- 1.7 Bidder hereby assigns to College any and all claims for overcharges associated with any resulting contract arising under antitrust laws of the United States, 15 U.S.C.A. Sec. 1 et seq. (1973) and the State of Texas, Tex. Bus. & Comm. Code Ann. Sec. 15.01, at seq. (1967).
- 1.8 The Vendor ID Number is the taxpayer number assigned and used by the Comptroller of Public Accounts of Texas. If the Vendor ID number is not known, enter bidder's Federal Employer's Identification Number, or Social Security Number if a sole owner. (Disclosure of SSN, if applicable, is mandatory pursuant to Section 231.005, Texas Family Code, and will be used in determining whether any person having 25% or greater ownership interest in the bidder company is more than 30 days delinquent in paying child support.)
- 1.9 In case of tie bids, any award will be made pursuant to Texas Bldg. & Procurement Comm. Rule 1; T.A.C. Section 113.6 (b)(3)(8) (preferences).
- 1.10 Bidder shall not assign any resulting contractor purchase order without prior written approval from the College.
- 1.11 Each proposal shall include a cashier's check or certified check, or acceptable bidder's bond payable to the Owner in the amount of not less than 5% of the largest total of the bid submitted.
- 1.12 A payment bond in the amount of 100% of the full contract amount will be required on all contracts over \$100,000.
- 1.13 A payment performance bond in the amount of 100% of the full contract amount will be required on all contracts over \$100,000.
- 1.14 Substitutions will not be allowed after a proposal has been submitted for consideration.
- 1.15 All addenda and/or cancellations will be issued in writing by College or its designee.

### 2. SPECIFICATIONS:

- 2.1 Unless specifically stated otherwise, any catalog, brand name or manufacturer's reference used in this Invitation is descriptive (not restrictive), and is used to indicate type and quality desired. Bids on brands of like nature and quality will be considered. If bidding on other than referenced specifications, the bid MUST show manufacturer brand or trade name and description of product offered. Illustrations and complete descriptions of product offered should be made part of the bid. If bidder does not identify exceptions to the specifications shown in this Invitation, bidder will be required to furnish brand names, numbers, etc., as shown in the Invitation.
- 2.2 All items bid shall be new, in first class condition, including containers suitable for shipment and storage, unless otherwise indicated in this Invitation. Verbal agreements to the contrary will not be recognized.
- 2.3 Bidder warrants fault free performance in the processing of date and date related data (including, but not limited to, calculating, comparing and sequencing) by the product(s) identified on this Invitation. Fault free performance includes, but is not limited to,

## EXHIBIT E

the manipulation of data with dates prior to, through, and beyond January 1, 2000, and during leap years, and performance shall be transparent to the user.

### 3. DELIVERY:

- 3.1 Bid should show the number of days required to deliver items to College's designated location under normal conditions. Unrealistically short or long delivery promises may cause bid to be disregarded. Failure to state delivery time obligates bidder to complete delivery in 14 calendar days.
- 3.2 The Texas Hazard Communication Act (Article 5182b, VTCS) requires chemical manufacturers and distributors to provide Material Safety Data Sheets (MSDSs) for hazardous materials sold. Products covered by this Act must be accompanied by a MSDS, and such products must be labeled in compliance with the law. For any product not covered under the Act, a statement of exemption must be provided.

### 4. BIDDER AFFIRMATION: BY SIGNATURE HEREON,

- 4.1 Bidder affirms that it has not given or offered to give, and does not intend to give at any time hereafter any economic opportunity, future employment, gift, loan, gratuity, special discount, trip, favor, or service to a public servant in connection with the submitted bid. Failure to sign the bid may, and signing it with a false statement shall, void the submitted bid or any resulting contract and bidder will be removed from all bid lists.
- 4.2 Bidder affirms that no kinship, relationship, or affiliation exists between owners, officers, administrators and employees of the bidder and the College which could be construed as a conflict of interest.
- 4.3 Bidder certifies that it is not currently delinquent in the payment of any franchise tax owed the State of Texas under Chapter 171, Texas Tax Code. Bidder acknowledges that making a false statement as to its corporate tax status is a material breach of any resulting contract.
- 4.4 Bidder certifies that neither the bidder nor any firm, corporation, partnership or institution represented by bidder, or anyone acting for any such entity, has violated the antitrust laws of this State, (codified in Section 15.01 et seq., Texas Business and Commerce Code), or the Federal Antitrust Laws, or communicated directly or indirectly the bid made to any competitor or any other person engaged in such line of business.
- 4.5 Bidder has not received compensation for participation in the preparation of the specifications for this Invitation to Bid.
- 4.6 Under Section 2155.004, Texas Government Code (re: collecting state and local sales and use taxes) bidder certifies that the individual or entity named in its bid is not ineligible to receive the specified contract, which may be terminated and/or payment withheld if certification is inaccurate.
- 4.7 Bidder agrees that any payments due under any resulting contract will be applied towards any debt, including but not limited to delinquent taxes and child support that is owed to the State of Texas.
- 4.8 Bidder certifies, if awarded a contract, that bidder shall defend, indemnify, and hold harmless the Board of Trustees of Texas Southmost College, and all of their respective officers, agents and employees from and against all claims, actions, suits, demands, proceedings costs, damages, and liabilities, arising out of, connected with, or resulting from any acts or omissions of bidder, or any agent, employee, subcontractor or supplier of bidder in the execution or performance of the contract.

# **Netting Specifications and Detail**

# **Net Connection**

## **SPORT AND GOLF NETTING**

### **Specifications: Redden #18 Baseball Netting**

Netting: #18 3 ½" stretched mesh (1 ¾" bar measure), twisted knotted nylon netting with a average 174.3 Lb. single mesh breaking strength. Netting to be made of 100% Dupont type 66 high-grade nylon. Netting component shall be dyed black and urethane bonded.

All sections of the netting component to be constructed to a 3/8" braided black perimeter rope with parallel core, minimum 3,500 Lb. breaking strength.

Attachment of net and rope components to be made with #48 braided polyester twine, 375 Lb. tensile strength, treated black. The attachment twine shall continually encompass the netting component and be tied to the rope component with a clove and one half hitch knot +/- 6 inches on center never to exceed 8 inches on center.

#### **\*Component Specifications/Tolerance**

##### **Netting Component:**

- ~ Dupont type 66 high grade nylon
- ~ 3 Strand twisted & knotted construction
- ~ 3.5 inch stretch mesh / 1.75 inch opening
- ~ Dyed black and urethane bonded
- ~ 174.3 lb. Average single mesh break strength<sup>1</sup>

##### **Attachment Twine / Hanging Twine:**

- ~ #48 braided polyester twine
- ~ 375 lb. Tensile strength
- ~ Dye treated

##### **Perimeter Border Rope & Ribline / Verticals:**

- ~ Braided synthetic cover
- ~ Parallel synthetic core
- ~ 3,500 lb. Tensile strength

**Warranty:** ~ Five year pro-rated limited warranty

# NET CONNECTION

877-818-0871

## TYPICAL POLE SPAN SECTION

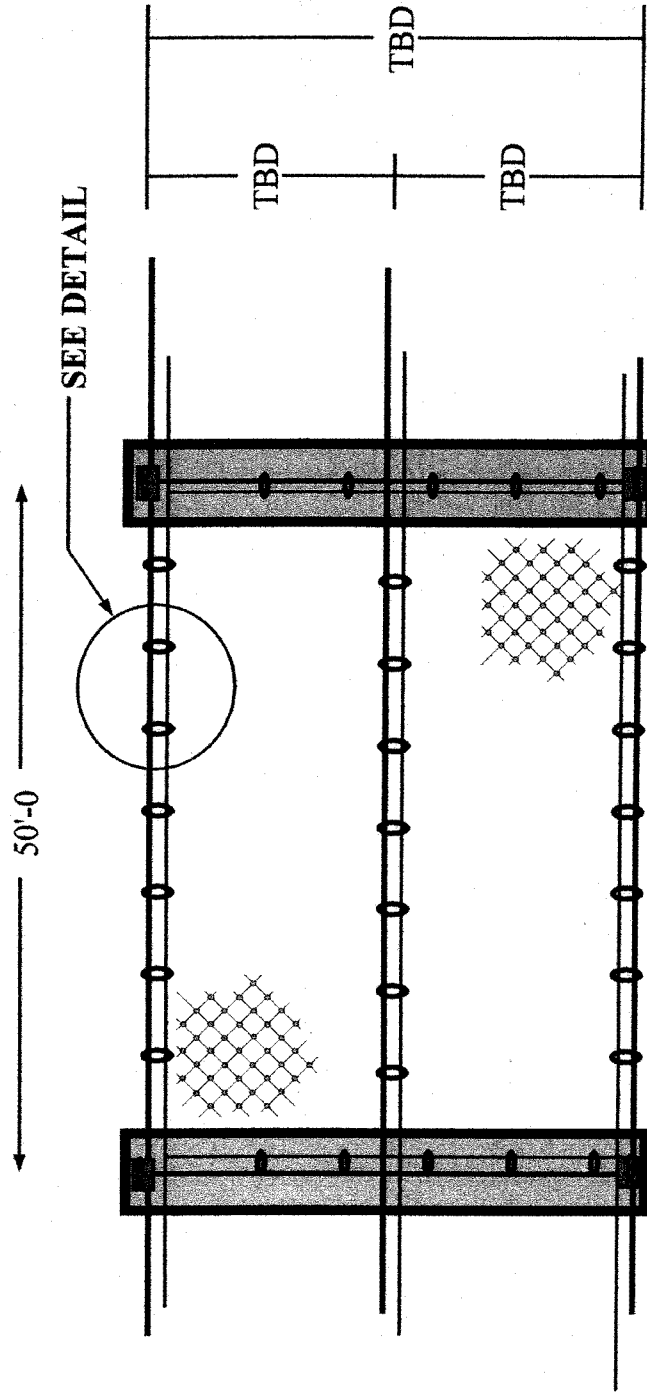

POLE SPANS APPROX. 50' O.C. THE MIDDLE OF EACH POLE SHALL HAVE A VERTICAL SUPPORT CABLE AND CORRESPONDING ROPE SUPPORTS (RIBLINES). HORIZONTAL ROPE AND CABLE SUPPORTS AT INCREMENTS TO BE DETERMINED.



**BID BOND**

(NOT VALID IF BID AMOUNT EXCEEDS \$ 65,000. )

KNOW ALL MEN BY THESE PRESENTS: That we, NET CONNECTION, LLC

as Principal, and the EMPLOYERS MUTUAL CASUALTY COMPANY, a corporation organized and existing under the laws of the State of Iowa and authorized to do business in the State of TEXAS

, as Surety, are held and firmly bound unto the TEXAS SOUTHMOST COLLEGE

as obligee, in the sum of FIVE PERCENT OF THE AMOUNT OF BID DOLLARS, lawful money of the United States of America, to the payment of which sum of money well and truly to be made, the said Principal and Surety bind themselves, their and each of their heirs, executors, administrators, successors and assigns, jointly and severally, by these presents.

THE CONDITION OF THIS OBLIGATION IS SUCH, that, if the Obligee shall make any award to the Principal for: BASEBALL NETTING AND SUPPORT SYSTEM  
RFP NO: TSC RFP09-11

according to the terms of the proposal or bid made by the Principal therefor, and the Principal shall duly make and enter into a contract with the Obligee in accordance with the terms of such proposal or bid and award and shall give bond for the faithful performance thereof, with the EMPLOYERS MUTUAL CASUALTY COMPANY as Surety or with other Surety or Sureties approved by the Obligee; or if the Principal shall, in case of failure so to do, pay to the Obligee the damages which the Obligee may suffer by reason of such failure not exceeding the penalty of this bond, then this obligation shall be null and void; otherwise it shall be and remain in full force and effect.

Signed, Sealed and Dated this 16TH day of APRIL, 20 09

Mary Jane Howell  
Witness

NET CONNECTION, LLC  
Principal

By: \_\_\_\_\_

[Signature]  
Witness

**Employers Mutual Casualty Company**  
Surety

By: Lisa Worley  
LISA WORLEY, Attorney-in-Fact

CERTIFICATE OF AUTHORITY INDIVIDUAL ATTORNEY-IN-FACT

KNOW ALL MEN BY THESE PRESENTS, that:

- 1. Employers Mutual Casualty Company, an Iowa Corporation
2. EMCASCO Insurance Company, an Iowa Corporation
3. Union Insurance Company of Providence, an Iowa Corporation
4. Illinois EMCASCO Insurance Company, an Iowa Corporation
5. Dakota Fire Insurance Company, a North Dakota Corporation
6. EMC Property & Casualty Company, an Iowa Corporation
7. Hamilton Mutual Insurance Company, an Iowa Corporation

hereinafter referred to severally as "Company" and collectively as "Companies", each does, by these presents, make, constitute and appoint:

LISA WORLEY, INDIVIDUALLY, HOOVER, ALABAMA

its true and lawful attorney-in-fact, with full power and authority conferred to sign, seal, and execute its lawful bonds, undertakings, and other obligatory instruments of a similar nature as follows:

IN AN AMOUNT NOT EXCEEDING TWO MILLION DOLLARS (\$2,000,000.00)

and to bind each Company thereby as fully and to the same extent as if such instruments were signed by the duly authorized officers of each such Company, and all of the acts of said attorney pursuant to the authority hereby given are hereby ratified and confirmed.

The authority hereby granted shall expire AUGUST 1, 2011 unless sooner revoked

AUTHORITY FOR POWER OF ATTORNEY

This Power-of-Attorney is made and executed pursuant to and by the authority of the following resolution of the Boards of Directors of each of the Companies at a regularly scheduled meeting of each company duly called and held in 1999:

RESOLVED: The President and Chief Executive Officer, any Vice President, the Treasurer and the Secretary of Employers Mutual Casualty Company shall have power and authority to (1) appoint attorneys-in-fact and authorize them to execute on behalf of each Company and attach the seal of the Company thereto, bonds and undertakings, recognizances, contracts of indemnity and other writings obligatory in the nature thereof, and (2) to remove any such attorney-in-fact at any time and revoke the power and authority given to him or her.

IN WITNESS WHEREOF, the Companies have caused these presents to be signed for each by their officers as shown, and the Corporate seals to be hereto affixed this 6TH day of MAY 2008

Seals

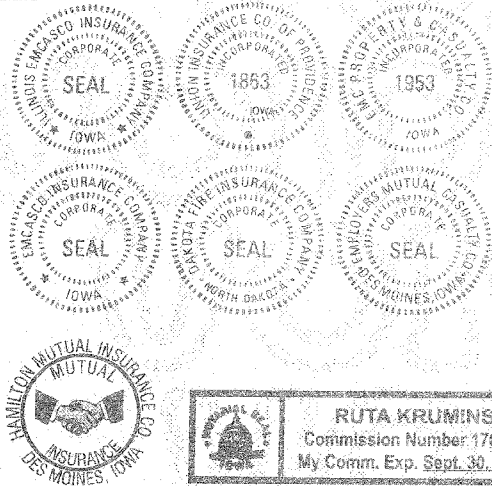

Bruce G. Kelley

Bruce G. Kelley, Chairman of Companies 2, 3, 4, 5 & 6, President of Company 1; Vice Chairman and CEO of Company 7

Jeffrey S. Birdsley

Jeffrey S. Birdsley, Assistant Secretary

On this 6TH day of MAY AD 2008 before me a Notary Public in and for the State of Iowa, personally appeared Bruce G. Kelley and Jeffrey S. Birdsley, who, being by me duly sworn, did say that they are, and are known to me to be the Chairman, President, Vice Chairman and CEO, and/or Assistant Secretary, respectively, of each of The Companies above; that the seals affixed to this instrument are the seals of said corporations; that said instrument was signed and sealed on behalf of each of the Companies by authority of their respective Boards of Directors; and that the said Bruce G. Kelley and Jeffrey S. Birdsley, as such officers, acknowledge the execution of said instrument to be the voluntary act and deed of each of the Companies. My Commission Expires September 30, 2009.

Rita Krumins

Notary Public in and for the State of Iowa

CERTIFICATE

I, David L. Hixenbaugh, Vice President of the Companies, do hereby certify that the foregoing resolution of the Boards of Directors by each of the Companies, and this Power of Attorney issued pursuant thereto on MAY 6, 2008 on behalf of Lisa Worley

are true and correct and are still in full force and effect.

In Testimony Whereof I have subscribed my name and affixed the facsimile seal of each Company this 16th day of April 2009

David L. Hixenbaugh

Vice-President



# TEXAS SOUTHMOST COLLEGE DISTRICT

## BOARD AGENDA REQUEST FORM

<b>Department/Division:</b> Planning and Construction Office/Partnership Affairs	<b>Board Meeting Date:</b> May14, 2009
<b>Agenda Item:</b> Consideration and possible action on a change order to the contract with Skanska USA for the Library Mural	
<b>Rationale/Background:</b> The TSC Board approved the design of the mural that would be displayed on the façade of the main entrance of the new Library. As we move forward to the completion of the project, there is a need to begin the fabrication and installation of the tile for the mural.  Skanska USA, contractor for the Library submitted a proposal for the work involved for fabrication and installation of the mural. The change order is for \$384,323. The change order has been reviewed and recommended by Broaddus and Associates project manager for the project.	
<b>Recommended Action:</b> This item will be presented to Physical Facilities Committee at their meeting on Thursday May 7, 2009 for the approval of the change order to Skanska USA .	
<b>Fiscal Implications:</b> Budgeted Item: <input checked="" type="checkbox"/> Yes <input type="checkbox"/> No <input type="checkbox"/> N/A If no, explain:	
<b>Attachments (List):</b> Change order form	

FOR OFFICE USE ONLY:

**Board Action:** Approved:  Yes  No  N/A  Tabled for action on: \_\_\_\_\_

**Certified by:** \_\_\_\_\_ **Title:** \_\_\_\_\_ **Date:** \_\_\_\_\_

# CHANGE ORDER

Date: May 5, 2009

Project No. & Name: Professional Zone Projects  
 Institution: Texas Southmost College  
 Contractor Name: Skanska USA  
 Change Order No.: **Three(03)**

To:

You are hereby authorized to make the following changes in the work under your contract;

C.P./F.O.

<u>No.</u>	<u>Description of Work</u>	<u>Cost</u>	<u>Time Extension</u>
01	Mural tile installation and procurement	\$384,323	229 days
<b>Total Change Order Amount:</b>		<b>\$384,323</b>	<b>229 days</b>

**(Refer Attachment "A" for Item Re-cap)**

It is mutually agreed that the payment of \$384,323 (\$) and 229 calendar days time extension provided for in this Change Order, constitutes full compensation to the Contractor, whether direct, consequential or otherwise, in any way incidental to, or arising out of, or resulting directly from the work performed or modified by the Contractor under this Change Order.

The new Substantial Completion date, including this time extension, if any is: December 29, 2009

The new Final Completion date, including this time extension, if any is: January 29, 2010

For the above changes the sum of \$384,323 (\$) will be added to the Contract Price as follows:

Original Contract Price:	\$20,124,325	ACCEPTED:
Previous Additions:	0	
Previous Deductions:	0	By _____ <i>Skanska USA</i>
		Date _____
Net Balance Contract Price:	\$20,124,325	APPROVED:
THIS Addition:	\$384,323	By _____ <i>Veronica Mendez - Assistant Vice-President for Planning and Construction - UTB/TSC</i>
		Date _____
Adjusted Contract Price:	\$20,508,648	By _____ <i>PM Diana Bravo Gonzalez</i>
		Date _____

# GUARANTEED MAXIMUM PRICE CONTRACT SUMMARY

Texas Southmost College

(To be used as a back-up summary for all GMP Contract and Owner's Construction Contingency Change Orders)

CO/CP/FO No.: 03

Submittal Date: May 5, 2009

Project No.: \_\_\_\_\_

Project Name: Professional Zone Projects- East Library, Classrooms and Thermal Plant  
Texas Southmost College

	<u>Previous Contract Price*</u>		<u>This Contract Price</u>		<u>Total Contract Price</u>
1. Cost of the Work:	<u>\$16,943,599</u>	+	<u>\$ 0</u>	=	<u>\$16,943,599</u>
2. General Conditions:	<u>\$1,499,468</u>	+	<u>\$ 0</u>	=	<u>\$1,499,468</u>
3. Construction Contingency:					
	<u>\$547,557</u>		<u>\$ 0</u>	=	<u>\$547,557</u>
4. Construction Phase Fee:	<u>\$586,144</u>	+	<u>\$ 0</u>	=	<u>\$586,144</u>
5. Owner's Special Cash Allowance:	<u>\$ 0</u>	+	<u>\$ 0</u>	=	<u>\$ 0</u>
6. Owner's Contingency:					
	<u>\$547,557</u>	+	<u>\$384,323</u>	=	<u>\$931,880</u>
7. TOTAL OF GMP LINE ITEMS 1 THROUGH 6:	<u>\$20,124,325</u>	+	<u>\$0</u>	=	<u>\$20,508,643</u>

\* Includes ALL changes to previous GMP(s).



# TEXAS SOUTHMOST COLLEGE DISTRICT

## BOARD AGENDA REQUEST FORM

<b>Department/Division:</b> Office for Planning and Construction	<b>Board Meeting Date:</b> May 14, 2009
<b>Agenda Item:</b> Consideration and possible action on substantial completion of the construction of the New Library and the Classroom Building	
<b>Rationale/Background:</b> <p>In August 2007, the Board authorized Skanska USA as the construction manager at risk to proceed with the construction of the New Library and the Classroom Building.</p> <p>The New Library would provide a comprehensive library and instructional support services to students, faculty, staff and community members. The Classroom Building plans to address the need for additional general purpose classrooms of larger sizes. The contract with Skanska was for construction of 43,279 sq. ft. Library and a 37,289 sq. ft. Classroom Building as well as Thermal pant improvements. The construction of the New Library includes fourteen offices for instructional support staff and Distance Education staff, an open computer lab, sixteen study rooms, a learning research area with three listening rooms, two conference rooms and an Internet Café. The Classroom building includes five medium classrooms with a capacity for 48 students, three large classrooms with a capacity for 98 students, two extra large classrooms with a capacity for 138 students, ten faculty offices and a Dean's suite. Kell Munoz, from San Antonio was the Architect and Broaddus &amp; Associates served as Project Manager.</p> <p>Substantial Completion inspections took place on May 5-6, 2009. The project management team and architect consider the project to be substantially complete. Final completion is scheduled for May 23, 2009.</p>	
<b>Recommended Action:</b> Motion to accept Substantial Completion of the New Library and Classroom Building and authorize the Assistant Vice President for Planning and Construction to close the project upon completion of punch list items.	
<b>Fiscal Implications:</b> Budgeted Item: <input checked="" type="checkbox"/> Yes <input type="checkbox"/> No <input type="checkbox"/> N/A If no, explain:	
<b>Attachments (List):</b> Substantial Completion Form	

<b>FOR OFFICE USE ONLY:</b>
<b>Board Action:</b> Approved: <input type="checkbox"/> Yes <input type="checkbox"/> No <input type="checkbox"/> N/A <input type="checkbox"/> Tabled for action on: _____
<b>Certified by:</b> _____ <b>Title:</b> _____ <b>Date:</b> _____

## Substantial Completion Acceptance

Project Name: Large Classroom Building & Professional zone Site work  
 Project No.: \_\_\_\_\_ Date of Issuance: 05/05/2009  
 Owner: Texas Southmost College  
 Contractor: Skanska USA  
 A/E Firm: Kell Munoz Architects Inc

### Scope of Work Covered by This Acceptance:

Interior and Exterior Building finishes and equipment except Men's and Women's restrooms

All site work, landscaping and Irrigation for both East Library and Classroom Buildings

Effective Date & Time of Acceptance: 5/7/2009 upon submittal of  
the certificate of occupancy

This constitutes the Owner's acceptance for Beneficial Occupancy: Yes  No   
 OCIP Worker's Compensation will terminate within sixty (60) calendar days: Yes  No  Not OCIP

In accordance with the Uniform General and Supplementary General Conditions (UGC) of the Contract, this is to confirm the results of the substantial completion inspection(s). The "punch list(s)" of items remaining to be completed or corrected as of the effective date of this acceptance, is formally issued by the Architect under separate cover. It is expressly understood that the failure to include any items on such list(s) does not alter the responsibility of the Contractor to complete all Work in accordance with the Contract Documents. In accordance with the UGC, the Date of Substantial Completion is that Date jointly certified by the Architect/Engineer, Owner and Contractor that the Work is sufficiently completed for the Owner to utilize it, or designated portion thereof, for the intended purpose.

As of the effective date noted above, the Contractor is relieved of the responsibilities for utilities, maintenance, security, custodial services, and insurance coverage, which may pertain specifically to the Work, covered by this acceptance. The Contractor remains responsible; however, to maintain full insurance coverage as required by the Contract for any areas of the project not yet accepted, and such coverage as may be necessary for its employees and subcontractors while engaged in completion of the punch list items as identified above.

The Owner and A/E will continue to inspect the entire project, including the work accepted herein, until final completion and acceptance of all elements of the work. This inspection will cover such defects as may have been overlooked as well as the items currently remaining on the punch list(s). During the guarantee and warranty period, the Owner will directly notify the Contractor of other defects that may appear.

The <b>Contractor</b> shall complete/correct the items identified on the punch list(s) within <u>30</u> Calendar days from the Effective Date of this Acceptance.		
_____	_____	_____
<i>Josue Reyes Senior Project Manager Skanska USA</i>	<i>Signature</i>	<i>Date</i>

The <b>Architect/Engineer</b> agrees that the Work noted in this Acceptance is sufficiently complete to be used as intended.		
_____	_____	_____
<i>Jim Sterner Partner Kell Munoz Architects</i>	<i>Signature</i>	<i>Date</i>

With the exception of those items noted on the attached "punch list(s)", the <b>Owner</b> accepts the Work designated herein as Substantially Complete as of the Effective Date of this Acceptance.		
_____	_____	_____
<i>Veronica Mendez Assistant Vice President for Planning and Construction</i>	<i>Signature</i>	<i>Date</i>



## Substantial Completion Acceptance

Project Name: East Library & Thermal Plant  
 Project No.: \_\_\_\_\_ Date of Issuance: 05/06/2009  
 Owner: Texas Southmost College  
 Contractor: Skanska USA  
 A/E Firm: Kell Munoz Architects Inc

### Scope of Work Covered by This Acceptance:

Interior and Exterior Building finishes and equipment except Men's and Women's restrooms

Effective Date & Time of Acceptance: 5/7/2009 upon submittal of the certificate of occupancy

This constitutes the Owner's acceptance for Beneficial Occupancy: Yes  No   
 OCIP Worker's Compensation will terminate within sixty (60) calendar days: Yes  No  Not OCIP

In accordance with the Uniform General and Supplementary General Conditions (UGC) of the Contract, this is to confirm the results of the substantial completion inspection(s). The "punch list(s)" of items remaining to be completed or corrected as of the effective date of this acceptance, is formally issued by the Architect under separate cover. It is expressly understood that the failure to include any items on such list(s) does not alter the responsibility of the Contractor to complete all Work in accordance with the Contract Documents. In accordance with the UGC, the Date of Substantial Completion is that Date jointly certified by the Architect/Engineer, Owner and Contractor that the Work is sufficiently completed for the Owner to utilize it, or designated portion thereof, for the intended purpose.

As of the effective date noted above, the Contractor is relieved of the responsibilities for utilities, maintenance, security, custodial services, and insurance coverage, which may pertain specifically to the Work, covered by this acceptance. The Contractor remains responsible; however, to maintain full insurance coverage as required by the Contract for any areas of the project not yet accepted, and such coverage as may be necessary for its employees and subcontractors while engaged in completion of the punch list items as identified above.

The Owner and A/E will continue to inspect the entire project, including the work accepted herein, until final completion and acceptance of all elements of the work. This inspection will cover such defects as may have been overlooked as well as the items currently remaining on the punch list(s). During the guarantee and warranty period, the Owner will directly notify the Contractor of other defects that may appear.

The **Contractor** shall complete/correct the items identified on the punch list(s) within 30 Calendar days from the Effective Date of this Acceptance.

\_\_\_\_\_  
*Josue Reyes Senior Project Manager*  
 Skanska USA

\_\_\_\_\_  
*Signature*

\_\_\_\_\_  
*Date*

The **Architect/Engineer** agrees that the Work noted in this Acceptance is sufficiently complete to be used as intended.

\_\_\_\_\_  
*Jim Sterner Partner*  
 Kell Munoz Architects

\_\_\_\_\_  
*Signature*

\_\_\_\_\_  
*Date*

With the exception of those items noted on the attached "punch list(s)", the **Owner** accepts the Work designated herein as Substantially Complete as of the Effective Date of this Acceptance.

\_\_\_\_\_  
*Veronica Mendez*  
 Assistant Vice President for Planning  
 and Construction

\_\_\_\_\_  
*Signature*

\_\_\_\_\_  
*Date*